

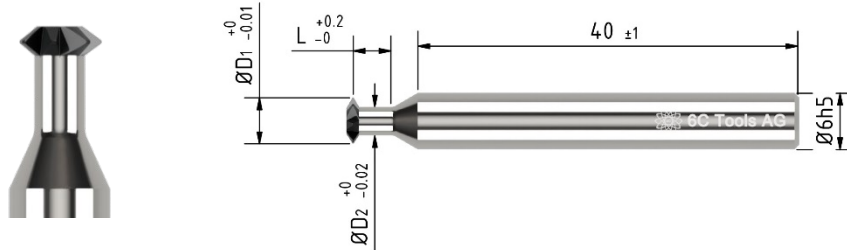

Thread Mill M



| Item Number | M | P | D ₁ | L ₁ | D ₂ | Z | Pre Hole \varnothing |
|-------------------------|------|------|----------------|----------------|----------------|---|------------------------|
| THM-P-2010-073-250-M1.0 | M1.0 | 0.25 | 0.73 | 2.5 | 0.43 | 5 | 0.8 |
| THM-P-2010-090-250-M1.2 | M1.2 | 0.25 | 0.9 | 2.5 | 0.57 | 6 | 0.98 |
| THM-P-2010-105-300-M1.4 | M1.4 | 0.3 | 1.05 | 3 | 0.66 | 6 | 1.14 |
| THM-P-2010-120-350-M1.6 | M1.6 | 0.35 | 1.2 | 3.5 | 0.78 | 6 | 1.32 |
| THM-P-2010-140-350-M1.8 | M1.8 | 0.35 | 1.4 | 3.5 | 0.98 | 7 | 1.52 |
| THM-P-2010-155-400-M2.0 | M2.0 | 0.4 | 1.55 | 4 | 1.05 | 7 | 1.67 |
| THM-P-2010-170-450-M2.2 | M2.2 | 0.45 | 1.7 | 4.5 | 1.14 | 7 | 1.83 |
| THM-P-3020-200-090-M2.5 | M2.5 | 0.45 | 2.0 | 9 | 1.44 | 8 | 2.13 |
| THM-P-3020-235-100-M3.0 | M3.0 | 0.5 | 2.35 | 10 | 1.6 | 8 | 2.5 |
| THM-P-3020-275-120-M3.5 | M3.5 | 0.6 | 2.75 | 12 | 1.85 | 8 | 2.9 |
| THM-P-3020-315-140-M4.0 | M4.0 | 0.7 | 3.15 | 14 | 2.1 | 8 | 3.3 |

Example: Thread Mill L/P=10 → -2010; D₁=1.55mm → -155; L₁=4.0mm → -400 → THM-P-2010-155-400-M2.0

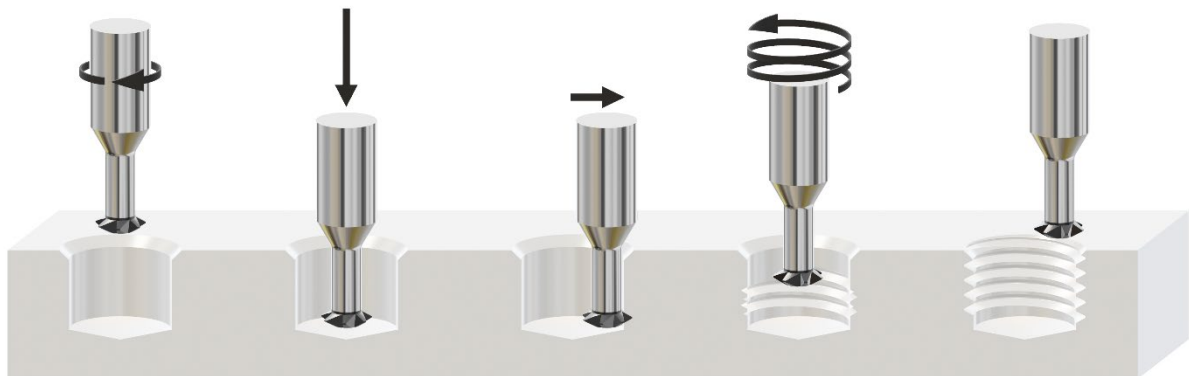



Thread Mill S

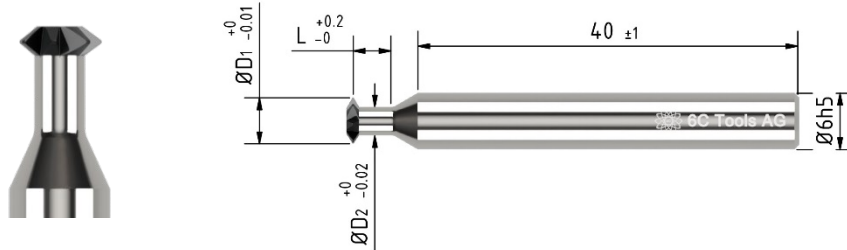

| Item Number | S | P | D ₁ | L ₁ | D ₂ | Z | Pre Hole \varnothing |
|-------------------------|------|-------|----------------|----------------|----------------|---|------------------------|
| THM-P-2010-046-150-S0.6 | S0.6 | 0.15 | 0.46 | 1.5 | 0.31 | 5 | 0.5 |
| THM-P-2010-053-180-S0.7 | S0.7 | 0.175 | 0.53 | 1.8 | 0.35 | 5 | 0.58 |
| THM-P-2010-061-200-S0.8 | S0.8 | 0.2 | 0.61 | 2 | 0.4 | 5 | 0.66 |
| THM-P-2010-075-250-S1.0 | S1.0 | 0.25 | 0.75 | 2.5 | 0.48 | 5 | 0.82 |
| THM-P-2010-090-250-S1.2 | S1.2 | 0.25 | 0.9 | 2.5 | 0.62 | 5 | 1.02 |
| THM-P-2010-105-300-S1.4 | S1.4 | 0.3 | 1.05 | 3 | 0.7 | 5 | 1.17 |

Example: Thread Mill L/P=10 → -2010; D₁=0.9mm → -090; L₁=2.5mm → -250 → THM-P-2010-090-250-S1.2

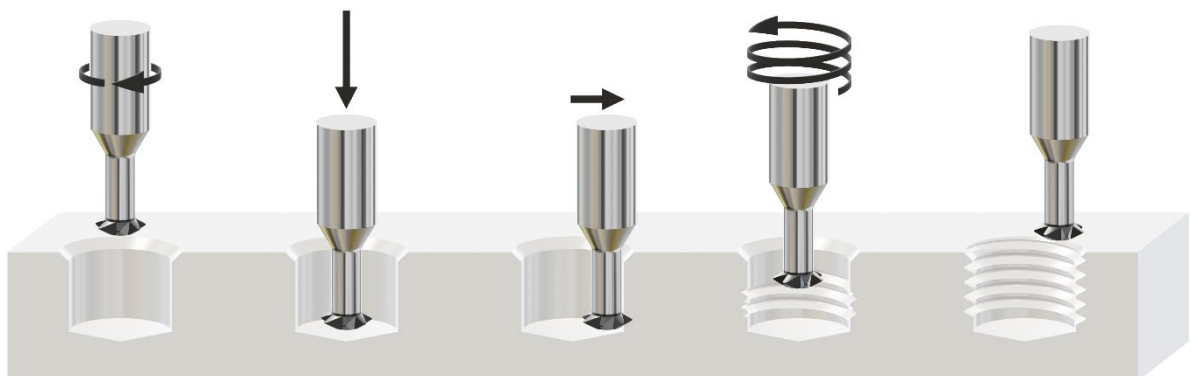



Thread Mill UNF / UNC

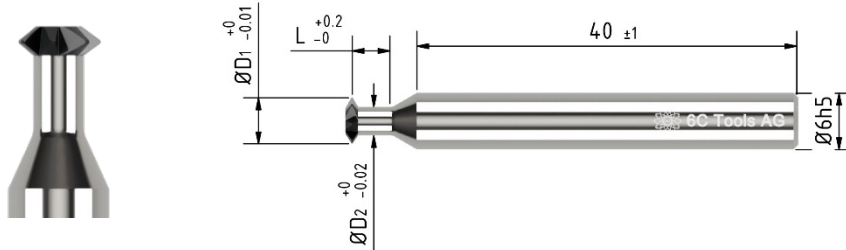

| Item Number | UNF/ UNC | P | D ₁ | L ₁ | D ₂ | Z | Pre Hole Ø |
|-----------------------------|-------------|-------|----------------|----------------|----------------|---|------------|
| THM-P-2010-140-400-N1-64UNC | #1-64UNC | 0.397 | 1.4 | 4 | 0.85 | 6 | 1.5 |
| THM-P-2010-165-450-N2-56UNC | #2-56UNC | 0.453 | 1.65 | 4.5 | 1 | 6 | 1.78 |
| THM-P-2010-110-320-N0-80UNF | #0-80UNF | 0.318 | 1.1 | 3.2 | 0.65 | 5 | 1.25 |
| THM-P-2010-140-350-N1-72UNF | #1-72UNF | 0.353 | 1.4 | 3.5 | 0.9 | 6 | 1.55 |
| THM-P-2010-175-400-N2-64UNF | #2-64UNF | 0.397 | 1.75 | 4 | 1.25 | 7 | 1.9 |
| THM-P-2010-200-450-N3-56UNF | #3-56UNF | 0.453 | 2 | 4.5 | 1.4 | 7 | 2.15 |
| THM-P-3020-190-106-N3-48UNC | #3-48UNC | 0.529 | 1.9 | 10.6 | 1.15 | 6 | 2.05 |
| THM-P-3020-210-127-N4-40UNC | #4-40UNC | 0.635 | 2.1 | 12.7 | 1.2 | 6 | 2.27 |
| THM-P-3020-240-127-N5-40UNC | #5-40UNC | 0.635 | 2.4 | 12.7 | 1.5 | 6 | 2.59 |
| THM-P-3020-260-159-N6-32UNC | #6-32UNC | 0.794 | 2.6 | 15.9 | 1.45 | 5 | 2.77 |
| THM-P-3020-310-159-N8-32UNC | #8-32UNC | 0.794 | 3.1 | 15.9 | 1.9 | 6 | 3.42 |
| THM-P-3020-220-106-N4-48UNF | #4-48UNF | 0.529 | 2.2 | 10.6 | 1.5 | 7 | 2.4 |
| THM-P-3020-250-115-N5-44UNF | #5-44UNF | 0.577 | 2.5 | 11.5 | 1.75 | 7 | 2.7 |
| THM-P-3020-270-127-N6-40UNF | #6-40UNF | 0.635 | 2.7 | 12.7 | 1.85 | 7 | 2.95 |

Example: Thread Mill L/P=10 → -2010; D₁=2.0mm → -200; L₁=4.5mm → -450

→ THM-P-2010-200-450-N3-56UNF

